

**Portascope.com**

**PVSUSB6100**

# **INSTRUCTIONS**

**VIDEO PVSUSB SCOPE**

## **IMPORTANT**

Please read this entire manual carefully before use the instrument. The manual contains pertinent information on the proper method of use and caution of your new VIDEO PVSUSB SCOPE. Although VIDEO PVSUSB SCOPE by nature are delicate instruments, proper operation and cleaning, as described in this manual, will greatly reduce the need for costly repair and extend the life of your new instrument.

This manual describes the recommended procedure for preparation and inspection the equipment before use. It does not elaborate on how the actual procedure is to be performed. Nor does it attempt to make a beginner familiarize with endoscope technique and the medical aspects of endoscope. This instrument should be used only by physicians who have received the training in the art of endoscope.

The safety and performance of an VIDEO PVSUSB SCOPE system depends not only upon the VIDEO PVSUSB SCOPE, but also on any ancillary equipment used with it. To ensure compatibility, it is recommended that you use only accessories confirmed<sup>1</sup>

As the products are ameliorated constantly, there maybe some difference between the products we provide with the products described in the manual in the aspect of the shape and the specification of the products.

If you have any questions concerning the material contained in this manual or concerning the operation or safety of the equipment, please contact or your [Portascope.com](http://Portascope.com) representative.

### **RECEIVING THE EQUIPMENT AND CAUTION**

Please check each item in the set against the list of standard components found in chapter 3. Contact [Portascope.com](http://Portascope.com) Service Center [EndoscopeRepair.com](http://EndoscopeRepair.com) representative if there are any missing or defective parts. Please read “PERFORMANCE” and “MAIN SPECIFICATIONS” on chapter 1, and “NAME OF PARTS” on chapter 2. to become acquainted with the name and function of each part of the VIDEO ENDOSCOPE. Review the instrument preparation, inspection and cleaning procedures carefully.

The VIDEO PVSUSB SCOPE should be cleaning and disinfection before the first use.

The VIDEO PVSUSB SCOPE and accessories should be removed from the carrying case and stored as described in Section 6-4 Storage. The carrying case is not intended to be used for storage of the equipment. Retain the carrying case only for shipping or transporting the instrument.

## BEFORE USE

In addition to thoroughly reading this manual, also refer to the instruction manuals supplied with your light source, accessories and other ancillary equipment.



### CAUTION









The PVSUSB is a precision instrument. Its design incorporates many features to ensure patient safety. In particular, the angulation running button is constructed to provide smooth response and maximal deflection of the distal tip when normal force is applied to the deflection control knobs. Excessive pressure applied to the deflection control knobs will result in damage to the VIDEO PVSUSB SCOPE and may cause patient injury. Before introducing the instrument into the patient be certain that the deflection control locks are in the “Free” (“F”) position and that the distal tip moves without resistance. If abnormal resistance is encountered when introducing the instrument or when operating the deflection mechanism, do not use the instrument. Contact your representative [www.EndoscopeRepair.com](http://www.EndoscopeRepair.com)



### Warning

The leakage test is a must after use VIDEO PVSUSB SCOPE every time. Do not use it if you find any leak of water, and contact us or distributors for technical support. Otherwise it will cause big trouble and do a lot of damage to the PVSUSB SCOPE.

## CONVENTIONS

Symbol	Explanation
	The CE mark on this equipment indicates it has been tested to and conforms with the provisions noted within the 93/42/EEC MDD.
	BF type
	CONSULT INSTRUCTIONS FOR USE
	FOLLOW INSTRUCTION FOR USE
	DATE OF MANUFACTURE
	MANUFACTURER
	AUTHORISED REPRESENTATIVE IN THE EUROPEAN COMMUNITY
	SERIAL NUMBER
<b>IPX7</b>	WATERPROOF LEVEL

## CONTENTS

1. FEATURES AND MAIN SPECIFICATIONS.....	6
2. NAMES OF PARTS .....	7
3. STANDARD SET.....	9
4. PREPARATION AND INSPECTION BEFORE USE.....	9
5. OPERATING THE VIDEO BRONCHOSCOPE .....	12
6. MAINTENANCE AND CARE.....	14
7. Appendix I TESTING OF AIRPROOF PERFORMANCE FOR INSTRUMENTS).....	23
8. Appendix II CLEANING, DISINFECTION, AND STERILIZATION FOR SUCTION VALVE .....	24

## 1. FEATURES AND MAIN SPECIFICATIONS

### 1-1 Features

The **PVSUSB** is for diagnosis of small animal patients, it with removing suction control valve, has suction/ transfusion features, etc. VIDEO endoscope can be dipped in water fully for cleaning and disinfection.

### 1-2 Main Specifications

No.	Item	Parameter		Units
1	Angle of View	120		degree
2	Depth of View	3 ~ 100		mm
3	Working Length	600	1500	mm
4	Insertion Tube Diameter	$\Phi 5.9$		mm
5	Distal Rigid Diameter	$\Phi 5.8$		mm
6	Tip Deflection	UP 180 DOWN 130		degree
7	Instrument Channel Inner Diameter	$\geq \Phi 2.0$		mm

## 2. PARTS



windows pc

Portable Light Source

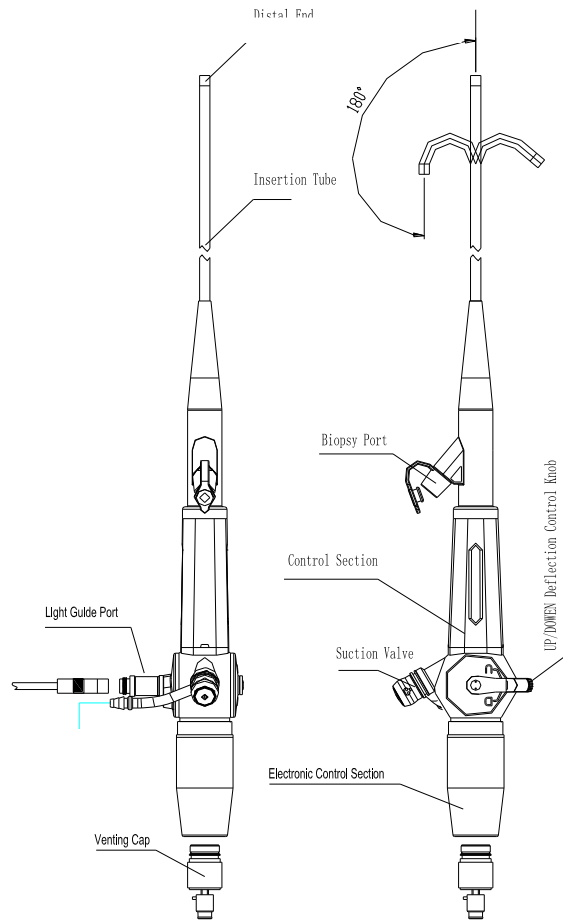
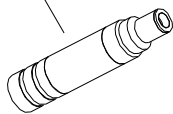

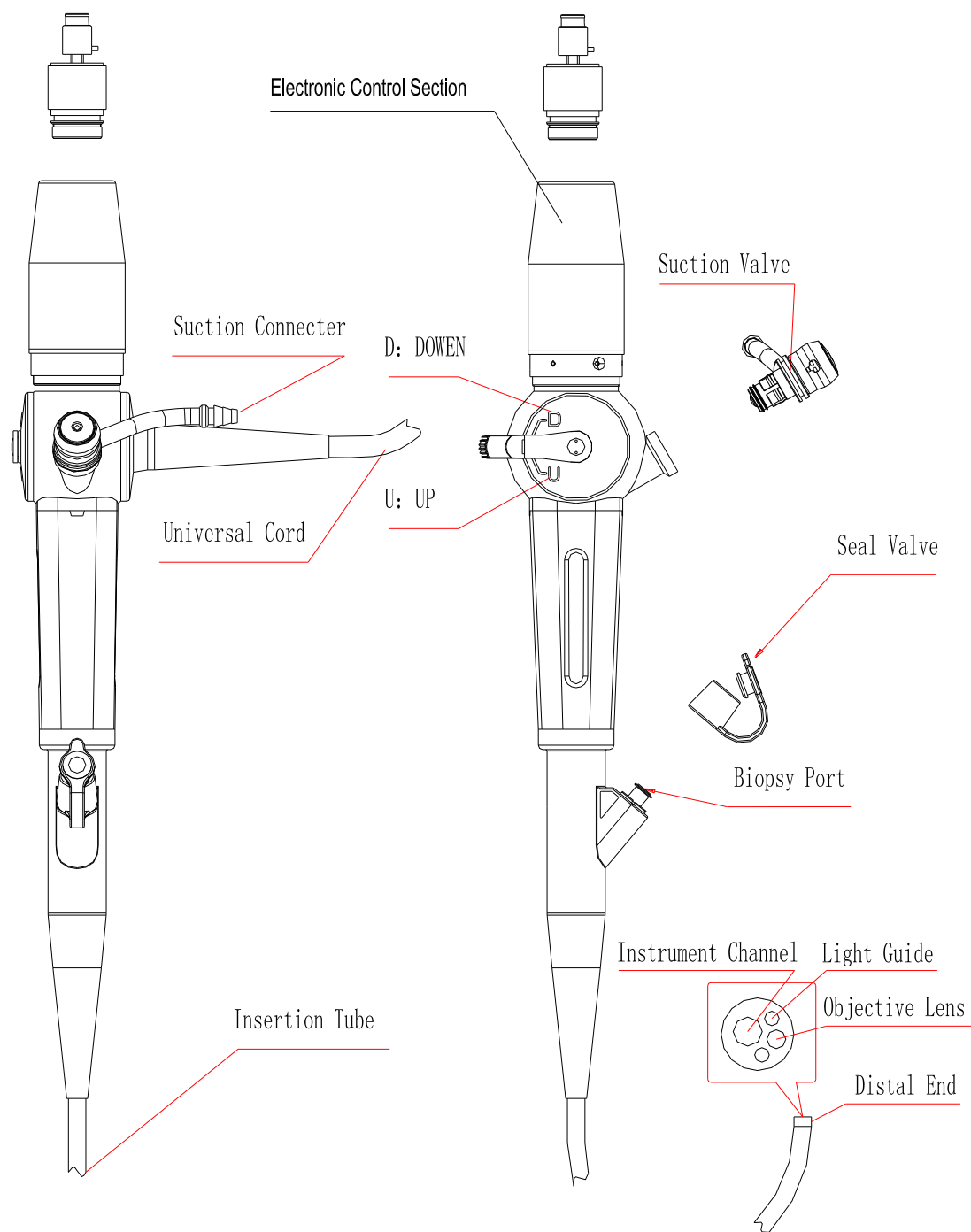



### 3. STANDARD SET

① VIDEO <b>PVSUSB</b> scope.....	1
② Biopsy Forceps.....	2
③ Channel Cleaning Brush .....	1
④ Cell Brush.....	1
⑤ Transfusion Tube .....	1
⑥ Channel Irrigator.....	1
⑦ Seal Valve.....	5
⑧ “O” Ring .....	4
⑨ Bite Block.....	5
⑩ Suction Valve .....	1

 **Only for 6 case per Suction Valve**

### 4. PREPARATION AND INSPECTION BEFORE USE

Also refer to the instruction manuals supplied with your light source, accessories and other ancillary equipment.

Environment of VIDEO **PVSUSB** SCOPE:

Temperature 10°C ~ 40°C; Humidity 30% ~ 80%;

Air Pressure 700hpa ~ 1060hpa

#### 4-1 Preparation of VIDEO Endoscope

Remove VIDEO Endoscope from storage area.

#### 4-2 Preparation and Inspection of Light Source

##### 1. Cold light source

###### ① Preparation

- Insert light guide connector of VIDEO **PVSUSB** scope to output receptacle of light source, and fix it.
- Plug the power cord (3-pin cord) into a properly grounded hospital grade receptacle (alternating current receptacle)

###### ② Inspection

Inspect the light source according to its instruction manual.

##### 2. Portable light source

###### ① Preparation

Take off the Light guide port then connect Video Bronchoscope with portable light source.

###### ② Inspection

Inspect the portable light source according to instruction manual.

#### 4-3 Preparation and Inspection of Biopsy Forceps

##### 1. Preparation

Select proper biopsy forceps for VIDEO Endoscope being used.

## Inspection

- ① Form a loop in the biopsy forceps approximately 20cm in diameter. Make sure that the forceps cups open and close smoothly when the handle is operated with light force.

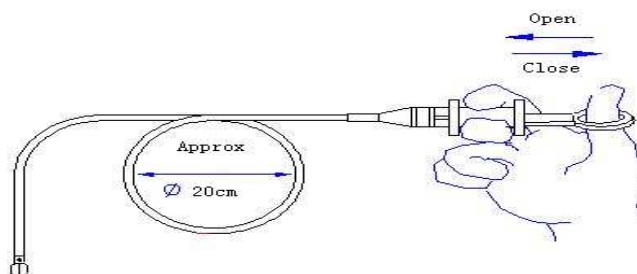

- ② Inspect other accessories following their individual instruction manuals.

⚠ Replace bent or kinked accessories.

⚠ If there is any irregularity in the operation or external appearance of a forceps, the forceps should be replaced with a new one.

### 4-4 Inspection of Suction function

- ① Press of suction do not more than 50kPa, confirm the suction pump can be worked.
- ② Connect the suction tube to the suction pump and to the suction connector on the handle of the endoscope.
- ③ Turn ON suction pump. Dip the distal tip in water, and suction is controlled by the endoscope's suction valve.  
(Below sketch map for reference)

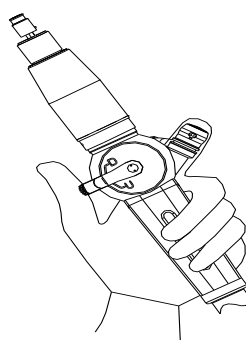

Sketch map for suction function

### 4-5 Inspection of the VIDEO Endoscope System

Before each use, the instrument should be inspected according to the following procedures. Should the slightest irregularity or abnormality be suspected, do not use the endoscope but contact **us**.

1. Inspection of the Insertion Tube
  - ① Inspect the surface of the insertion tube visually for any dents, bugles or other irregularities.
  - ② Run your fingertips over the whole length of the insertion tube checking for any protruding objects, internal looseness, or other irregularities.
2. Inspection of the Bending Section

Operate the deflection control knobs slowly and to the limit in each direction. Make sure the bending section bends smoothly and correctly and that maximum deflection can be achieved. Simultaneously inspect the outer surface of the bending section for small holes, breaks, or other irregularities.

**⚠** Do not bend or twist the bending section by hand while operating.

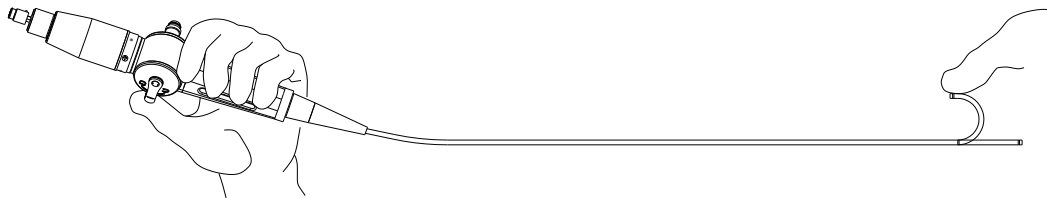

Sketch map for Bend shape

3. Inspection of the Instrument Channel
  - ① Pass the biopsy forceps through the channel to confirm smooth passage.
  - ② If forceps do not pass smoothly, do not force!

**⚠** Caution: Damage will occur to both biopsy forceps and instrument channel if excess force is applied.

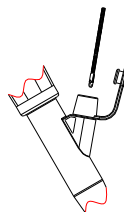

Sketch map for Channel insertion

4. Inspection of System
  - ① Connect light source with Video **PVSUSB** scope meanwhile connect videoscope with USB port of computer/laptop through

- ② Turn on computer/laptop, start up work station software, turn on light source.  
Observe if there's image on computer/laptop, inspect and adjust it.

#### 4-6 The Final Preparation Before Use

1. Cleaning and Disinfection of Instruments  
Clean or Disinfect the endoscope and accessories according to procedures.
2. Application of Silicone Wax (Lens Cleaner, Anti-Fogging Agent)  
Apply Silicone Wax (lens cleaner) to a piece of clean gauze and lightly wipe the objective lens and the light guide lens. Remove excess.
3. The Application of Lubricant  
Lubricate the insertion tube with a water-soluble medical grade lubricant, taking care to avoid the distal tip.

 Do not use olive oil, lignocaine ointment, petroleum based lubricants or vaseline based lubricants. Otherwise damage will occur to the material of the endoscope.

#### 5. Operating the VIDEO PVSUSB scope



##### Warning

There is a risk of thermal injury to tissue from prolonged exposure to the intense transillumination through an endoscope. Because of the increased light carrying capabilities of endoscopes combined with the high output of high-intensity light sources (especially Xenon Lamp), it is possible to convey a large amount of light energy and to concentrate this energy in a very small area (i.e. mucosa), thermal injury to the tissue may result.

The risk of injury is increased under the following conditions:

1. Prolonged close contact or close stationary viewing of the mucosa
2. Advancing the endoscope through a narrow lumen.
3. Using a high-intensity light source (Xenon).

The following recommendations will reduce risk of thermal injury:

1. Use the minimum level of illumination necessary for adequate visualization.
2. When possible, avoid close stationary viewing.

To prevent accidents, do not leave the endoscope plugged into the light source with the lamp on when not in use.

**Must have passed the train of clinical endoscope inspection technology if who operate this instrument. This manual only describe basal operation for related instrument.**

### **5-1. Holding VIDEO PVSUSBscope**

Holding the handle portion of VIDEO PVSUSB scope by left hand, holding insertion tube by right hand. Suction valve can be operated by left index finger, and up/down bending running button can be operated by pollex.

### **5-2. Insertion and inspection**

#### **1. Insert VIDEO PVSUSBscope**

Insert the VIDEO PVSUSB scope to mouth or nasal cavity lightly.

A gap can be seen on the view area edge when you observing, this symbol show up.

#### **2. Adjust luminance**

Adjust the luminance of light source, get comfortable luminance.

Maybe cause heat for distal end of VIDEO PVSUSB scope if use Xenon Lamp. There is a risk of thermal injury to tissue from prolonged exposure to the intense transillumination through an endoscope. Use the minimum level of illumination necessary for adequate visualization.

#### **3. Operation of Angulation**

Operate angulation running to lead bending portion as required. Up/down bending running button operated and fixed by left pollex, convenient for observing.( see figure on Page 10: Sketch map for Bend shape)

If it lose the control fuction of angulation, or occur any abnormality when operating, please stop inspection immediately. And put the angulation running button on the middle, than observing and pulling out the VIDEO scope lightly.

#### **4. Operation of Suction**

It will be difficult for observing when has impurity, please wipe out it by suction,also any liquid can be clean out by suction.

Connect the suction tube to the suction connector in the endoscope handle section, Switch ON the suction pump,press suction button by finger. Depress the suction valve and secretion will be aspirated.

Avoid pump mucosa close to suction port, please stop suction immediately if occur this phenomena. Pulling out the VIDEO scope a little and disengage the mucosa from suction port.

#### **5. Operation of Transfusion**

Connect the injector to the end of the transfusion tube. Insert the transfusion tube through the instrument channel and inject the solution to the proper position.

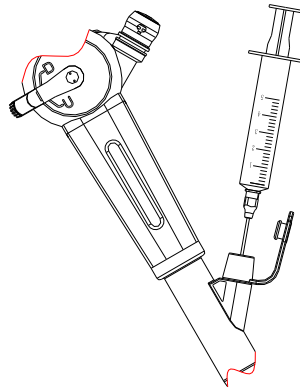

### **5-3. The Operation of the Biopsy**

Insert the biopsy forceps into the instrument channel, and let the assistant operator make the forceps cup in closed position. Slowly advance the forceps, and when the forceps comes into view, press the distal end of the forceps against the mucosa, and pull them into the scope with the distal end thus closed in case the mucosa falling off the distal end. Withdraw the forceps.

### **5-4. The Obtaining of the Fallen Cell Sample**

Insert the cell brush into the instrument channel. Slowly advance the brush, and when the brush comes into view, brush the cell fallen off. Then withdraw the cell brush back to the end of the instrument channel. Withdraw the endoscope accompany with the brush. After taking sample, withdraw cell brush from the instrument channel.

### **5-5. Pulling out the VIDEO Bronchoscope**

Confirm the bending portion of VIDEO **PVSUSB** scope on the flat position.( angulation running button in the middle)

Pulling out VIDEO **PVSUSB** scope slightly when observing.

## **6. Maintenance and Care**

### **6-1. Summary**

Cleaning,Disinfection and Sterilization procedures of VIDEO endoscope and accessories, please according to 《Technique operation rules for Cleaning and Disinfection of Endoscope》 .

VIDEO endoscopes and accessories must be thoroughly cleaned prior to disinfection or sterilization. Cleaning thoroughly will eliminate animalcule and organic materials, which have adverse effects on the disinfection/sterilization.

VIDEO endoscopes and accessories are made of materials in a manner,

which may not tolerate certain methods of cleaning/disinfection. Those procedures, as described below, have been thoroughly tested and found to have no adverse effects on durability of the instrument. Strict adherence to these procedures is highly recommended.

Endoscopes and accessories are designed for different kinds of disinfection methods. The decision of which methods should be employed by certain party should be made by the national / local relating department or the hospital's disinfection-preventing department.

Instruments		VIDEO Bronchoscope	Biopsy Forceps Bite Block Suction Valve
Cleaning & Disinfecting			
Cleaning	Ultrasonic	Not applicable	Applicable
	Solution	Applicable	Applicable
Disinfectant	70% alcohol (wipe)	Applicable	Applicable
	Glutaraldehyde Solution (dip in)	Applicable	Applicable

This VIDEO endoscope is waterproof fully, can be dip in solution for Cleaning & Disinfecting.

## 6-2. Cleaning of VIDEO PVSUSB scope

Initiate the following procedure immediately after each examination.

1. Wipe insertion tube with gauze, and remove the mucus.
2. Immerse insertion tube in cleaning solution, gently wipe insertion tube with gauze or sponge.
3. Cleaning, Disinfection and Sterilization of Suction Valve  
According to appendix 2 for operation in this manual, one suction valve only for 6 cases.
4. Cleaning of suction channel
  - (1) Clean the entire suction channel with cleaning brush
    - ① Pass cleaning brush through suction valve housing until the brush extends from the distal end of the instrument.  
Brush channel several times.
    - ② Insert cleaning brush into channel opening until the brush extends from the distal end of the instrument. Brush channel several times.

 Please insert the cleaning brush in the direction indicated in the picture. Do not attempt to pass cleaning brush in reverse direction until the brush head extends from the distal end of the endoscope. Use only the cleaning brush to clean the channel. Avoid damage the

## PVSUSB CHANNEL CLEANING

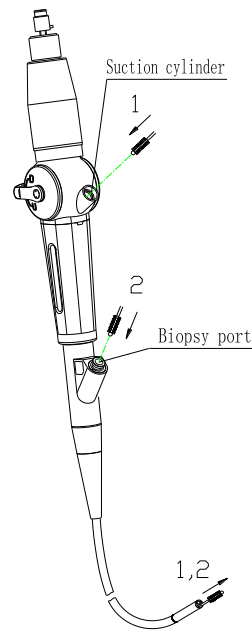

(2). Close in the insertion channel opening by finger, put the distal end in water for suction operation 10 second, alternately feed air and water to clean the channel.

### 5. Cleaning of plug jaws seal valve and plug jaws

Attach the channel irrigator to the suction valve of endoscope(as following figure), outpour and inbreathe disinfection solution or water, repeat operating for cleaning and disinfection thoroughly.

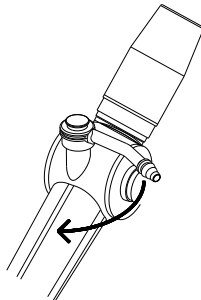

6. Immerse the insertion portion in washing solution, scrub all the outer surface and rinse it by water.

7. Pulling out the insertion portion of light guide from light source.

8. Wipe up the outer surface of VIDEO endoscope and cleaning channel.

9. Install plug jaws seal valve.

10. Use gauze with alcohol wipe up operation portion.

11. Testing of leakage

Attach the leakage tester to the leakage portion of endoscope, Pump the hand bulb until the indicator needle is within the test zone and still at 18Kpa (do not exceed this pressure), immerse the complete endoscope into the water (do not together with pressure gauge),



Observe the endoscope for about 30 seconds. If no bubble is observed from the instrument, the endoscope is watertight.(Please read airproof capability testing on the final page).

 If the indicator needle moves, a leakage is indicated, remove the endoscope from the water, and contact us for repair.

12. Endoscope can be immersed in water entirely when cleaning it. Observe the endoscope for about 30 seconds. If no bubble is observed from the instrument, the endoscope is watertight, it can be immersed in water entirely for cleaning and disinfection.

### **6-3. Disinfection of VIDEO PVSUSB scope**

Cleaning procedure can not serve the purpose of disinfection. The disinfection of endoscope requires the study of various disinfection methods and materials, which should be selected according to a professional view and special clinic condition.

- (1) Some materials used by the endoscope may cause damnification, if in incorrect disinfection methods. Prior to each disinfection, should pay attention to the security of instrument fully and adopt correct methods for cleaning and disinfecting. The following disinfectors have been thoroughly tested and found to have no adverse effects on durability of the endoscope:

Chlorhexidine solution      Glutaraldehyde solution(2%)      EOG

When disinfecting the instrument, especially using EOG, disinfection must under the following condition.

Pressure: under 1.5hpa      Temperature: under 40°C

 **The way of disinfection as below will cause serious malfunction to the VIDEO PVSUSB scope which should be prohibited.**

- I When pressure is over 1.5hpa and temperature is over 40°C, using EOG to disinfect the instrument.**
- II Clean and disinfect with ultrasonic**
- III Disinfect with boiled water**
- IV Desiccate sterilization to disinfect**
- V Disinfect with steam**
- VI Disinfect with cresol liquid**
- VII Using chloridize-benzene liquid which has not been diluted to disinfect the instrument.**

 If using other disinfection method than the recommended

method, please contact **US** to be informed of the durability of the endoscope. [www.EndoscopeRepair.com](http://www.EndoscopeRepair.com)

(2) **Cleaning/Disinfecting/Sterilizing the Biopsy Forceps**

The accessories should be thoroughly rinsing before disinfection.

( e.g. Biopsy Forceps, control clamp, etc.)

The use of ultrasonic cleaner is desirable to aid in the removal of particulate matter. If possible, the accessories should be sterilized with ethylene oxide gas, and should be cleaned with gas to eliminate the poisonous gas. When the sterilizing can not be done, immerse the entire accessories into the disinfection solution. Wash and dry them thoroughly. To avoid sticking, lubricate the forceps cups with a medical grade silicone lubricant or liquid lubricant.

#### **6-4 Storage of VIDEO Endoscope**

- ① The VIDEO Endoscope must be dried thoroughly prior to storing. Take special care to dry the distal tip, and all lens. Use a dry cotton swab to dry carefully the objective lens and light guide on the distal end. Apply lens cleaner (silicone wax) to a piece of clean gauze and lightly wipe the lens surface. This will prevent residue in tap water from leaving a film over the lens.



Do not wipe off the lens cleaner (silicone wax).

- ② Storage area must be clean, dry, well ventilated and maintained at a normal temperature. Avoid direct sunshine, high temperature, high humidity, and X-ray exposure.
- ③ The endoscope should be stored with the insertion tube as straight as possible. If it must be coiled for storage, do not coil insertion tube tighter than it's condition when in the instrument carrying case.
- ④ Do not use the carrying case for storage. The carrying case is designed for shipping purpose only. Routine storage of the endoscope in a humid, dark, non-ventilated environment, such as carrying case, may cause problems with infection control. Accessories (e.g. biopsy forceps), must also be dried thoroughly before storage. Do not coil tightly.

#### **6-5 Cautions in Transport and Storage**

The product is portable and should be transported and stored after packing. Pay attention to the following conditions in the process.

- ① Storage、transport ( Temperature/ Humidity/ Air Pressure Range )  
-40℃ ~ +55℃ / 10% ~ 93% / 500hpa ~ 1060hpa

- ③ Conditions of Working( Temperature/ Humidity/ Air Pressure Range )  
10°C~40°C/30%~80%/700hpa~1060hpa

## 6-6 Repair of VIDEO Endoscope

- ① Should the endoscope require repair, it should be shipped to [www.EndoscopeRepair.com](http://www.EndoscopeRepair.com) in it's original carrying case, along with a description of the instrument malfunction or damage. Include the address and postcode of the hospital, the name and telephone number of the individual most familiar with the instrument problem.
- ② Minor problems with the operation of the endoscope may be corrected by the operator or assistant. Refer to (6-8) TROUBLESHOOTING GUIDE. All other repairs should be only performed by \_\_\_\_\_ assumes no liability for any patient/user injury, instrument damage or malfunction due to repairs made by unauthorized personnel.

## 6-7 Expected service life and waste disposal

- ① The expected service life of endoscope is 5 years, more than this term do not use.
- ② Free throw of the electronic endoscope and the annex will be harmful to the environment, should be these Waste to the designated by the environmental protection department of the recycling points or sent back to the company for a unified treatment.

## NOTICE

 **For the purpose of infection control, and for the safety of all those who will handle the equipment, before returning any instrument to Huger, the instrument must be thoroughly cleaned and subjected to a high-level disinfection procedure. If the endoscope are used by patient with infectious disease(e.g. patient with HA positive), please inform the maintenance man of Huger.**

## 6-8 Disposal of VIDEO Endoscope and accessories

Disposing of VIDEO Endoscope and accessories optionally, this will bring harm to environment, please deliver to [1800Endoscope.com](http://1800Endoscope.com)

## 6-9 Troubleshooting Guide

Refer to the listed methods. If the problems still can't be solved, stop using the instrument and send to [www.EndoscopeRepair.com](http://www.EndoscopeRepair.com)

## TROUBLESHOOTING GUIDE

	Problem	Possible Cause	Solution
Image	Image appears unclearly	Dirty objective lens	Feed water to remove mucous, etc.
		There is bead or color list on image.	Stop using and return to <b>US</b> for repair
	No image	Signal cable hasn't been connected completely	Connect again
Suction Image	Absent or insufficient suction	Suction valve blocked.	Remove valve. Clean the port with cotton swab. Lubricate with petroleum-based lubricants.
		Suction channel blocked.	Remove suction tube. Depress the suction valve and apply more pressure to eliminate fragment from the tube. .
		plug jaws seal is not good	Replace with a new seal valve.
	Sticky suction valve	Suction Valve is dirty.	Remove and wash the valve. Clean the port by cotton swab with alcohol and lubricate with Petroleum based lubricants . Then re-attach it.
	Fluid or air leak from the biopsy valve.	Valve deterioration or missing	Replace with a new plug jaws seal valve..
	Angulation	Tip deflection is abnormal.	Tip deflection is less than specifications.

		There is interspace in angulation	encountered when rotating angulation control knobs, do not apply excessive force, otherwise early deterioration and damage will occur.
		Resistance is abnormal.	
		The outside of bending section is damaged	Stop using. Send back instrument for repair.
Accessory	Forceps do not operate smoothly	Forceps shaft is bent or kinked.	Discard and replace with new forceps
		Forceps cups dirty.	Soak in hot soapy water or hydrogen peroxide and brush to remove debris. The routine use of an ultrasonic cleaner to aid in cleaning the small sup hinges is recommended if problem does not persist ( Do not clean the endoscope by ultrasonic cleaner)Lubricator forceps with silicone oil
	Forceps do not pass through channel smoothly	Forceps shaft is bent or kinked.	Discard and replace with new forceps.

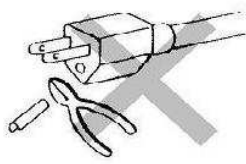

In case of current shock, all the light source and suction pump should be connected to the ground completely and securely.

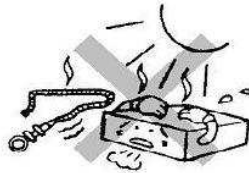

Direct sunlight, dust, high humidity and high temperature will damage instruments.

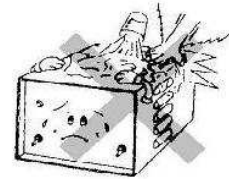

To prevent operator shock and damage to the equipment, keep spillable liquids away from electrical equipment.



Do not bend insertion tube in a tight radius, as this will damage delicate fiber bundles.

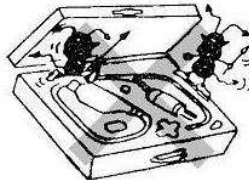

Do not store in the carrying case.

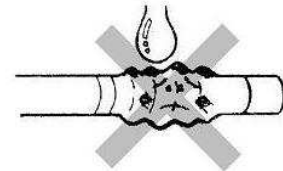

Petroleum based lubricants will cause stretching and deterioration of bending section rubber.

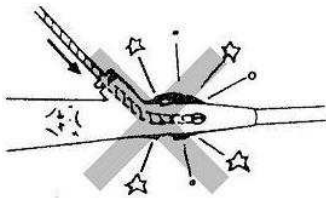

If forceps do not pass smoothly, do not force! Damage will occur to both biopsy forceps and instrument channel.

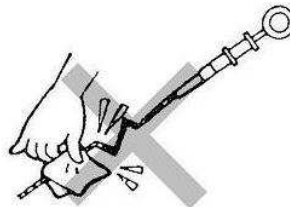

Do not apply excessive force.

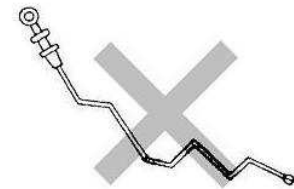

Any accessory which is kinked or bent along its shaft will not operate smoothly, will be difficult to pass through the video endoscope, and must be replaced.

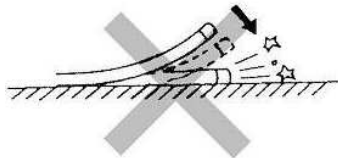

Do not let distal end strike a hard surface as this may crack the objective lens.



Do not use a needle or other sharp object to remove debris from air/water nozzle. The nozzle may be deformed or pried loose.

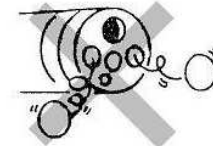

Do not autoclave or boil the video endoscope, nor clean the video endoscope with ultrasonic cleaner.

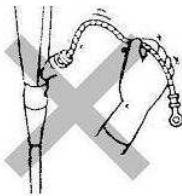

To prevent bending or kinking forceps shaft, hold forceps close to biopsy valve and advance using repeated, short strokes.

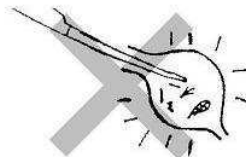

Excessive air feed may cause discomfort to the patient, or cause damage to the stomach.

## 7. Appendix I Testing of airproof performance for instruments

Testing of airproof performance for video endoscope is necessary before immerse the complete endoscope into the water for cleaning adisinfection. Cleaning and disinfection can be operated after the airproof performance is all right.

Detail method as following sketch map:

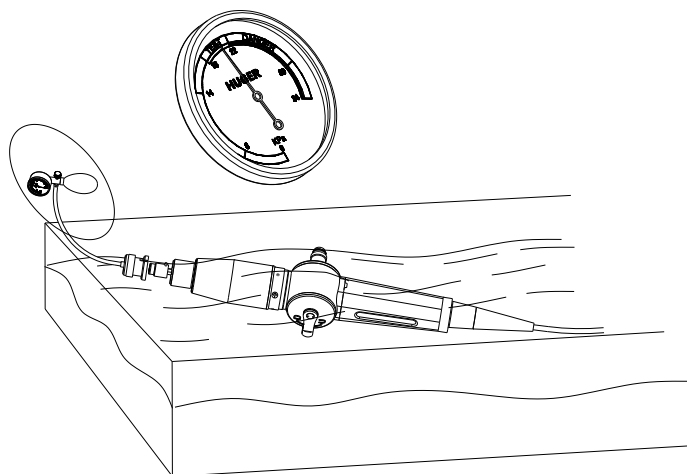

Attach the leakage tester to the leakage portion of endoscope, Pump the hand bulb until the indicator needle is within the test zone and still at 22Kpa (do not exceed this pressure).

Immerse the complete endoscope into the water when the indicator needle stop(do not immerse the elliptoid dashed circle portion into water as following sketch map), turn angulation running wheel, up and down for three times each. Observe the endoscope for within 3 minutes. If no bubble is observed from the instrument, the endoscope is watertight.(Remark: beginning of immerse the complete endoscope into the water, maybe has some air bubble, but this phenomenon is natural).

⚠ If the indicator needle moves, a leakage is indicated, remove the endoscope from the water, and contact **US** for repair.

**⚠** Warning



**The leakage test is a must after use VIDEO PVSUSB SCOPE every time. Do not use it if you find any leak of water, and contact HUGER or distributors for technical support. Otherwise it will cause big trouble and do a lot of damage to the PVSUSB SCOPE.**

## 8. Appendix II

### Guide of cleaning, disinfection, and sterilization for suction valve

#### 1) Signal words

The following signal words are used in appendix II

-  Explains the dangerous conditions that may cause to death or serious accident unless it is avoided.
-  Explains the conditions that may cause to light or medium injury unless it is avoided, also explains the conditions that may damage to equipment unless it is avoided.

**Note:** Indicates a supplementary information.

#### 2) Intended use

The suction valve assembled on suction cylinder of the PVSUSB Videoscope Pumping through the channel from distal end of endoscope, do not for other purpose but intended use.

#### 3) Operation

-  ● Has not do any disinfection and sterilization for suction valve before shipment. It sterilized with ethylene oxide gas or high temperature/ high pressure is necessary after cleaning. Cleaning, disinfection, and sterilization as sterilization procedures in Chapter Seven.
- Only for 6 cases per Suction Valve, if occur following irregularities, replace with a new suction valve immediately.
  - ① The suction valve is not secure and reliable after attached.
  - ② The solution fed with a syringe is aspirated into the suction container without operating the suction valve.
  - ④ The suction valve detach easily during use.
  - ⑤ Air is aspirated from the distal end of endoscope without operating the suction valve.
- Do not use the suction valve whose valve has been scratched or torn, also do not use the suction valve whose valve detached from main body easily, otherwise, suction may not stop.
- If suction cannot stop during use, disconnect the suction tube from the suction valve.

##### 3.1) Attaching the suction valve to the endoscope

-  Firmly attach the suction valve to the suction cylinder of the endoscope. If the suction valve is attached to the endoscope improperly



with a gap between the base of the suction valve and the top of the suction cylinder, the suction valve may detach from the endoscope and /or may cause patient debris to leak or spray from the gap, posing an infection-control risk.

- ① Place the suction valve into the suction cylinder, pay attention to the direction of the suction valve main body. Press the suction valve button with finger until it clicks into place. (see Figure 1).

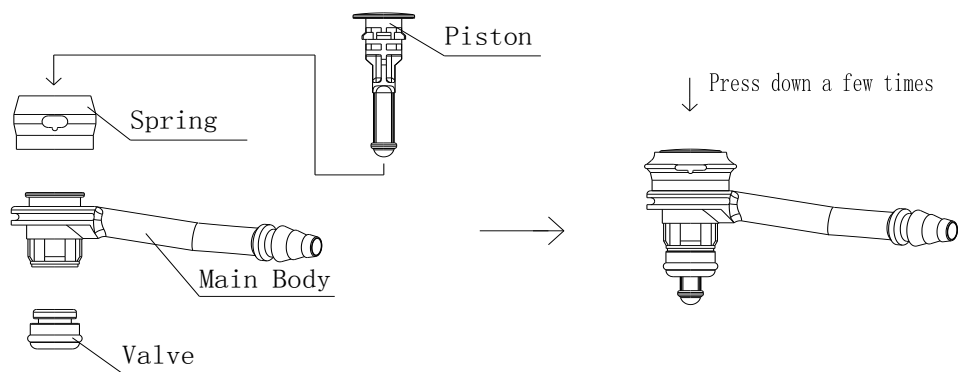

**Attachment of the suction valve**  
**Figure 1**

- ② Inspect and verify that the base of the suction valve is in contact with the suction cylinder properly. Improper attachment, where a gap still exists between the base of the suction valve and the top of the suction cylinder. (see Figure 2)

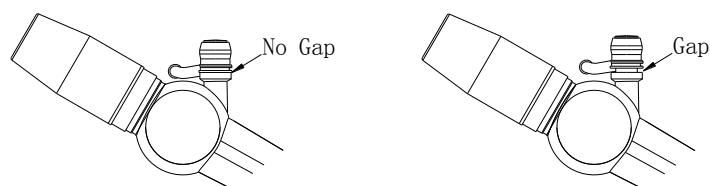

**Proper attachment**

**Improper attachment**

**Figure 2**

**Note:** Sometimes the suction valve will click before it is fully seated in the suction cylinder. Press the suction valve down firmly to ensure that it is fully seated in the suction cylinder.

### 3.2) Inspection before use

- ① Connect the suction tube to the suction connector. Turn on the suction pump.
- ② Place the distal end of the insertion tube in sterile water and depress the suction valve button. Confirm that water is continuously aspirated into the bottle of the suction pump. Release the valve and confirm that suction stop. After inspecting the suction function, remove the distal end from the water and aspirate air for 2 or 3 seconds to expel water from inside of the instrument channel.

### 3.3) Operation

Depress and hold the suction valve button to activate suction. Use the same method when aspirating with Endo-Therapy accessories in place.

### 3.4) Remove the suction valve from the endoscope.(see Figure 3)

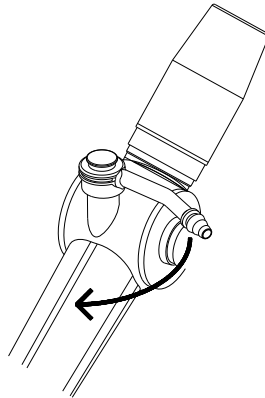

#### Remove the suction valve from the endoscope

Figure 3

- ① Rotate the suction connector clockwise with thumb.
- ② Remove the suction valve from the suction cylinder.

## 4) Cleaning, Disinfection and Sterilization



- Always wear personal protective equipment to guard against dangerous chemicals and potentially infectious material. Personal protective equipment includes eye wear, face mask, moisture-resistant clothing, and chemical-resistant gloves that fit properly and are long enough so that your skin is not exposed.
- The results of sterilization depend on various factors such as how the sterilized instrument was packed or the positioning, method of placing, and loading of the instrument in the sterilization device. Please verify sterilization efficacy by using biological or chemical indicators. Also, follow the guidelines for sterilization issued by medical administrative authorities, public organizations, or the infection control department at

your facility, as well as the instruction manual of the sterilization device.

**Note:** Use detergent solution for the time and at the temperature recommended by the solution manufacturer.

#### 4.1) Disassembling the suction valve (see Figure 4)

- ① Remove the piston, completely with spring, from the main body.
- ② Remove the spring from the piston.
- ③ Remove the valve from the main body.

#### 4.2) Cleaning (see Figure 5)

- ① Insert the channel opening cleaning brush into the main body opening and brush the inside.
- ② Insert the channel cleaning brush into the suction connector and brush the inside.
- ③ Brush the external surfaces of the main body and piston with a tooth brush in detergent solution.
- ④ Brush the inside of the spring and valve with the channel opening cleaning brush. Clean off the all parts with fingers. Brush the external surfaces with a tooth brush.
- ⑤ Place all parts in an ultrasonic cleaner running at 40 kHz and ultrasonically clean for 5 minutes.
- ⑥ Rinse all parts under running water.

**Note:** If mucus or blood remains, it can sometimes harden during immersion in disinfectant solution or autoclaving.

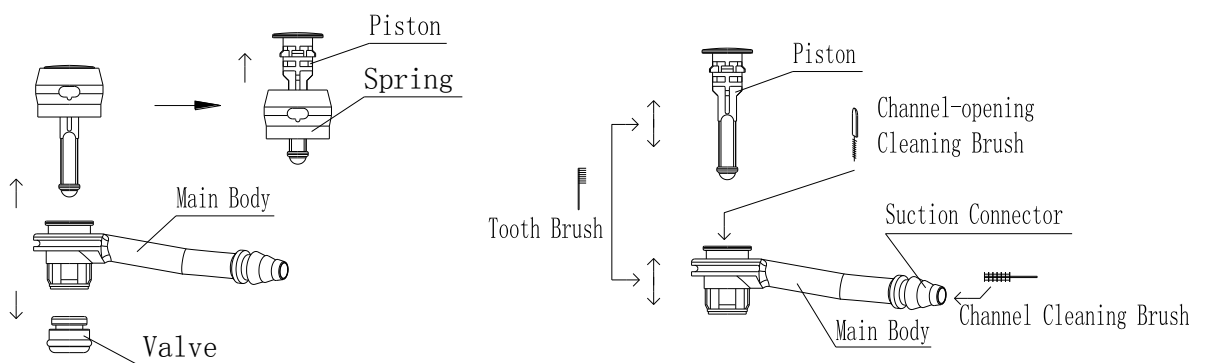

**Disassembling the suction valve**  
**Figure 4**

**Cleaning**  
**Figure 5**

#### 4.3) Disinfection

- ① Prepare disinfectant solution at a temperature and concentration according to the solution manufacturer's instruction.

- ② With the suction valve disassembled, immerse the four parts completely in disinfectant solution. Should air bubbles adhere to the external and/or internal surfaces, remove them using a clean, soft, lint-free cloth and/or 30ml syringe.
- ③ Soak the parts for the time and at the temperature recommended by the disinfectant manufacturer.
- ④ Remove the parts from disinfectant solution and gently agitate in sterile water to thoroughly rinse.
- ⑤ Remove the parts from the sterile water and thoroughly dry with a sterile, lint-free cloth.

#### 4.4) Sterilization

After cleaning, perform ethylene oxide gas sterilization or autoclave according to the parameters given in the instruction manual of the endoscope.

### 5.) Assembling and inspecting the suction valve

#### 5.1) Assembling the suction valve

- ① Press the valve into the main body as shown in Figure 6.
- ② Attach the spring to the top of the main body.
- ③ Insert the piston through the components as shown in Figure 6 and press down a few times.

#### 5.2) Inspection after assembling ( Figure 6)

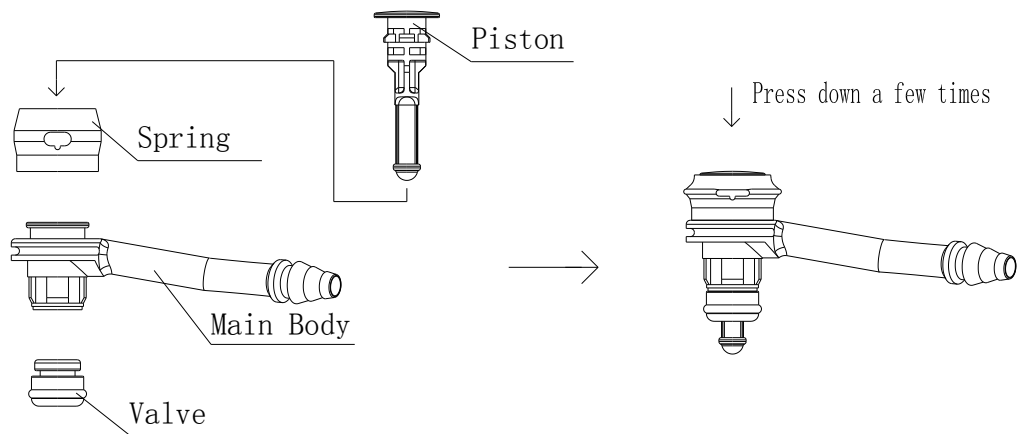

#### Assembling the suction valve

Figure 6

- ① Verify that the spring is correctly installed in the main body.
- ② Verify that the piston is attached to the spring and that the clearance between spring and the piston is small.

- ③ Verify that the valve is correctly attached to the main body.
- ④ Visually inspect the valve and the spring for cracks.

## 6.) Storage

Store the suction valve at ambient temperature, in a dry, clean location away from direct sunlight.



Do not store the suction valve in the carrying case. Use the carrying case only for shipping the endoscope. Routinely storing the suction valve in a humid, nonventilated environment such as the carrying case may present an infection control risk.

## 7.) Disposal



After use, dispose of this suction valve in an appropriate manner. If it is not properly disposed of, it could pose an infection control risk.

After using this suction valve, dispose of it in an appropriate manner.